

**INSTALLATION, OPERATION AND
MAINTENANCE MANUAL**

**Steam – Water – Mixing Valve
MODEL: MX1N**



MIYAWAKI INC.

Osaka, Japan

CONTENTS

- 1. Initial System Requirements**
- 2. Installation**
- 3. Operation of the Mixing Valve**
- 4. Troubleshooting**
- 5. Maintenance**
- 6. Parts List**

1. Initial System Requirements

- (1) The pressure ratio between the steam supply and cold water supply must not exceed 3:1 or 1:3. Ratios greater than this will not allow the mixing valve to obtain its specified hot water output. For optimum results it is recommended that pressure reducing regulator be installed on the higher of the two supplies to adjust the ratio to 1:1.
- (2) Confirm that the required steam flow to the mixing valve is available. Steam consumption in lbs/hr. is approximately one half of the water temperature rise in degrees F. per GPM of hot water flow.

$$\text{Steam lbs/hr} = \frac{\text{Water Temperature Rise } ^\circ\text{F}}{2} \times \text{Hot Water Flow GPM}$$

- (3) It is recommended that the following components be on-hand prior to the installation
 - Globe Valve - 1 pcs.
 - Strainer - 2 pcs.
 - Check Valves - 2 pcs.
 - Dowels and screws for the Valve Body - 4 pcs.
 - Union - 3 pcs.
 - Ball Valve - 2 pcs.
 - Thermometer - 1 pcs.
 - Pressure Gauge - 2 pcs.

2. Installation

(1) Fix the Mixing Valve with the Bottom Flange to the wall.

Dimensions:

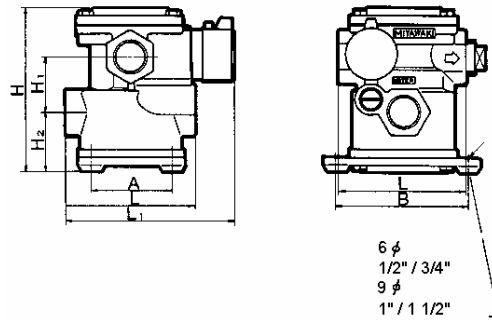

Fig. 1

Connections	Size	Dimensions <i>inches and millimeters</i>						
		L	L1	H	H1	H2	A	B
Screwed	1/2"	3.9	5.4	5.3	1.7	1.8	2.4	4.0
	3/4"	100	138	134	43	47	62	102
	1"	5.5	7.0	6.6	2.2	2.0	3.4	5.8
	1 1/2"	140	179	168	57	51	86	147
		6.3	7.4	7.8	2.8	2.4	3.4	5.8
		160	189	197	70	60	86	147

(2) Connect the steam pipe to the steam inlet of the valve and the cold water pipe to the water inlet of the valve (Refer to the marks "STEAM" and "WATER" on the body).

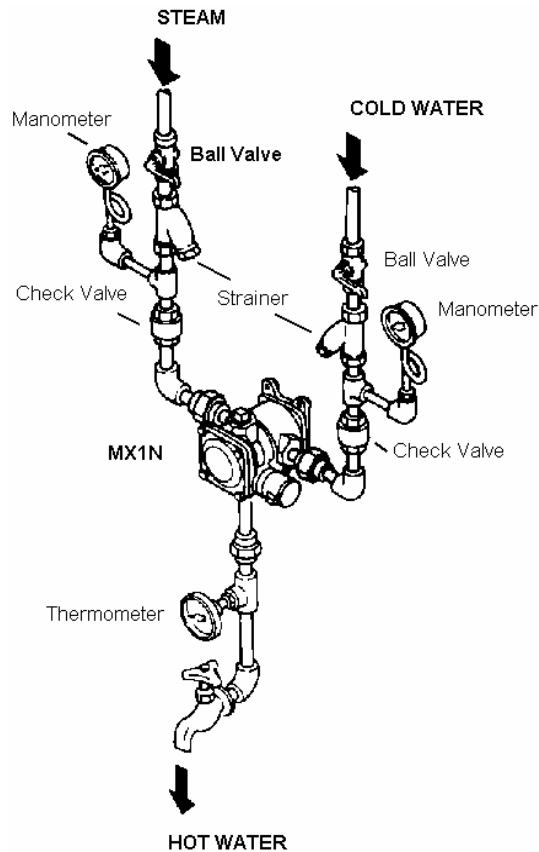
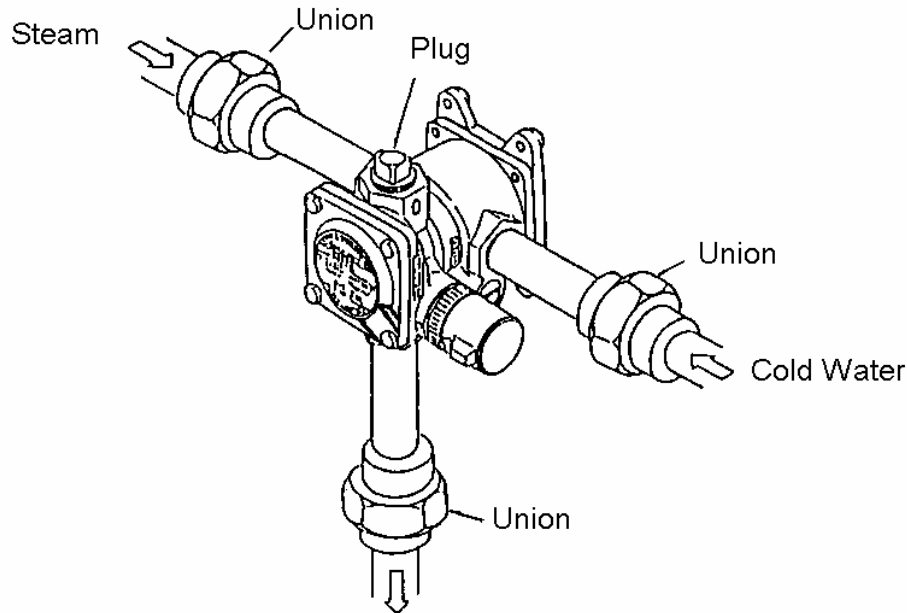

Fig. 2

- (3) The Mixing Valve has two outlets. One of them is closed by a plug. Dependent on the requirements each outlet can be used.
- (4) To remove the Mixing Valve easily for maintenance it is recommended to connect all pipes with unions to the valve.

Fig. 3



- (6) A globe valve must be installed at the hot water outlet to allow adjustment to the water flow through the mixing valve. The mixing valve will only operate properly when the flow rates are within the specified values shown on the MX1N Capacity Data Sheets.
- (7) In case of fluctuating steam pressure it is recommended to install a steam pressure reducing valve (we recommend Type RE from MIYAWAKI) to stabilize the pressure. The same should be done in case of unstable water pressure. The operation of the Mixing Valve may be adversely affected by unstable supply pressures.
- (7) Please, install only items with low flow resistance in the hot water line (for instance take Ball valves with full bore) to reduce the back pressure to a minimum.

3. Operation of the Mixing Valve

For safety reasons the blue handle is set at cold water temperature at the time of delivery.

When using the Mixing Valve the first time, please, pay attention to the following:

- (1) Open the cold water inlet and the hot water outlet and check that the cold water is discharging from the hot water outlet.
- (2) Now open slowly the ball valve at the steam inlet pipe. Turn the blue handle slowly to the right until stopped by the red safety button. Do not push the red safety button. The hot water must reach now a temperature of about 40°C (104°F).

Fig. 4

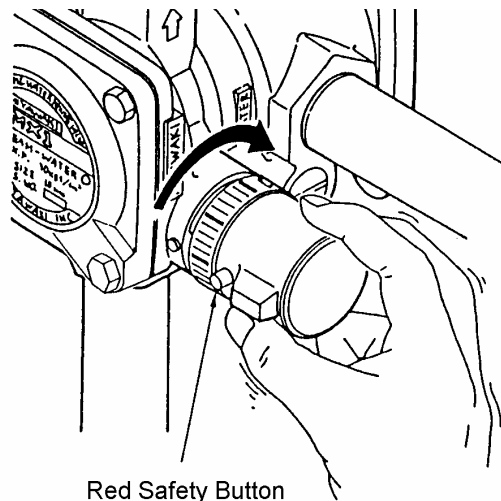

- (3) In case a higher hot water temperature is requested, push the red safety button and turn the blue handle to the right. Stop when the requested hot water temperature will be reached.

Fig. 5

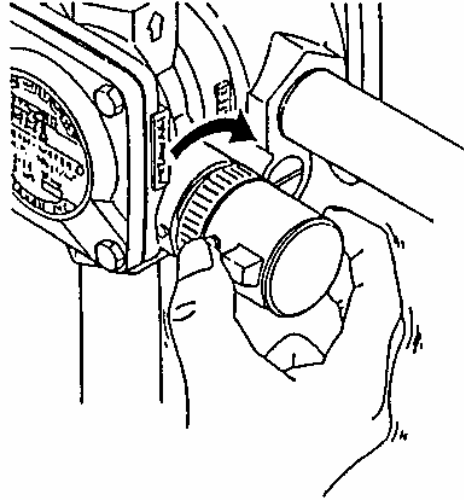

4. Troubleshooting

Trouble	Possible Problem	Measures
No hot water	Ratio of steam pressure to water pressure is higher than 3:1 or 1:3 (see point 1.1).	Change the steam or water pressure until the necessary ratio will be reached.
	The cold water pressure is lower than 0,35 bar (5 psig).	Increase water pressure
	The hot water flow is smaller than the requested minimum flow (see point 1.3.).	Change the pipe size. If not possible contact MIYAWAKI.
	The steam inlet valve is closed.	Open the steam inlet slowly.
	The steam side strainer is plugged	Clean the strainer.
	No steam is coming to the inlet.	Check, whether the check valve is installed correctly.
	Internal strainer (No. 42) is plugged.	Clean the strainer.
	Diaphragm (No. 11) is not working.	Change the diaphragm.
	Diaphragm unit is not working.	Check, whether the shaft can be moved. If not, clean the shaft.
	Bimetal unit is not working (rusty).	Change the bimetal unit.
Hot Water is flowing only	Either steam pressure or	Try to stabilize the inlet

temporarily.	water pressure are fluctuating rapidly.	steam and water pressure.
The blue knob is turned to lower temperature, but temperature remains high.	The main valve is not closing.	Clean the main valve. If there will be no result, change the main valve unit.
	The shaft of the diaphragm unit is not moving.	Clean the shaft or change it.
	The bimetal unit is not working.	Change the bimetal unit.

5. Maintenance

5.1. Disassembly of the Valve

(1) Loose the cover bolts (No. 48 and No. 71, 4 pcs.)

Valve Size	Cover bolt size
1/2"	10 mm
3/4"	10 mm
1"	17 mm
1 1/2"	17 mm

Fig. 6

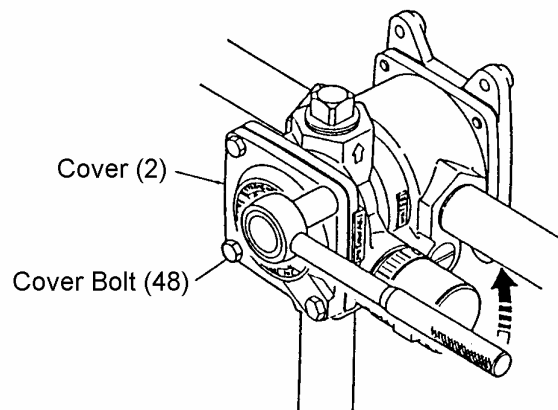

(2) Take out the Diaphragm Unit carefully not damaging the diaphragm. Pay attention, that the 1/2" and 3/4" – Valves have a pressure valve spring which may jump out.

Fig. 7-A

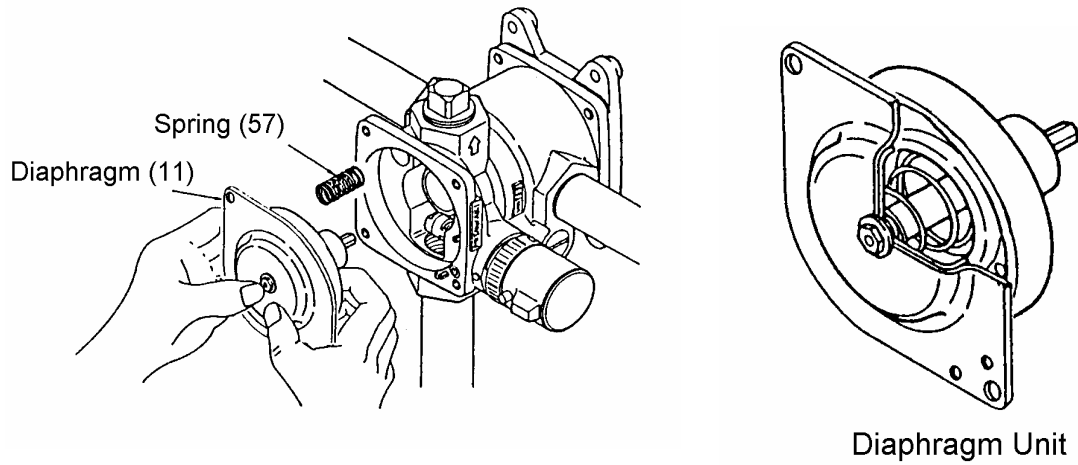

Fig. 7-B

- (3) Remove the handle cap by a screwdriver (Fig. 8-A).
Loose the screw (No. 41) by a driver (Fig. 8-B) and remove the handle from the adjust unit (Fig. 8-C).

Fig. 8-A

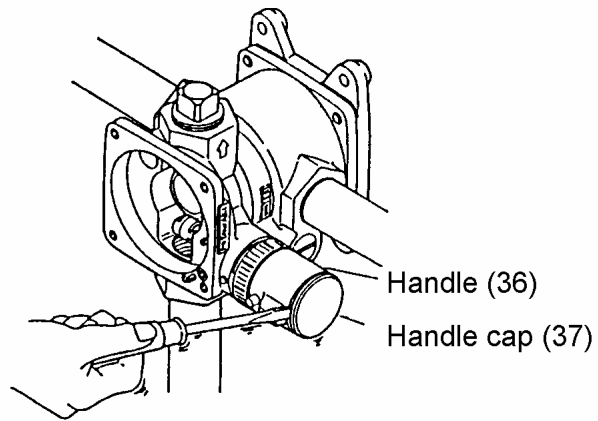

Fig. 8-B

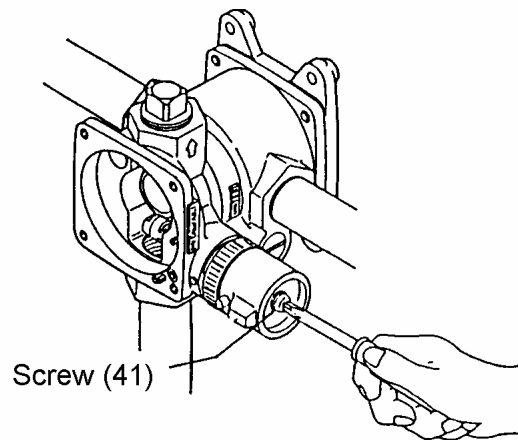
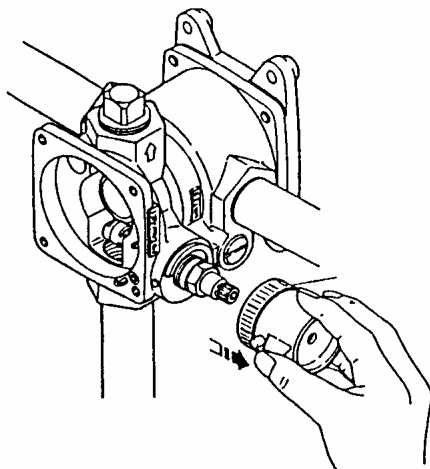
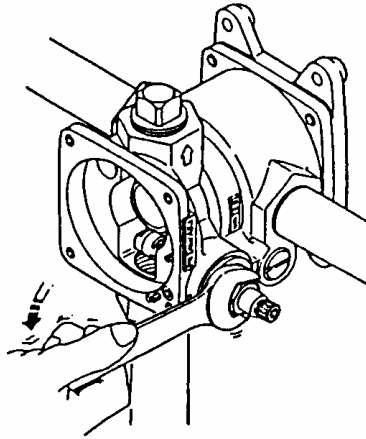

Fig. 8-C



(4) Loose the bush (No. 35) and take it out (Fig. 9-A).

Fig. 9-A



By pushing with a screwdriver towards the bimetal unit, the bimetal unit can be taken out easily (Fig. 9-B).

Fig. 9-B

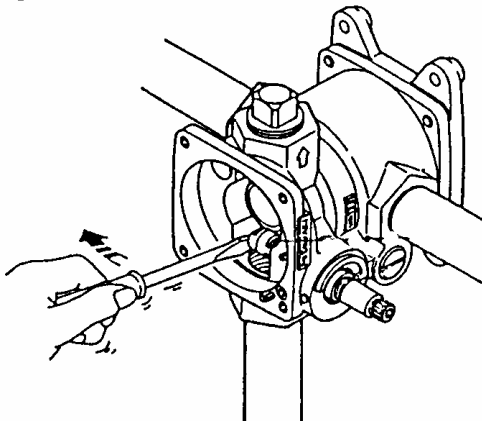

Bimetal and Adjust Unit

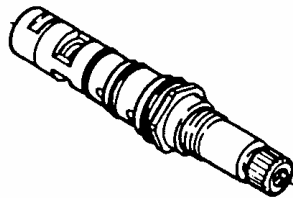

(5) The Main Valve can be removed by loosening the main valve seat with a socket wrench (Fig. 10-A).

Valve Size	Socket wrench Size
------------	--------------------

Fig. 10-A



1/2"	27 mm
3/4"	27 mm
1"	38 mm
1 1/2"	46 mm

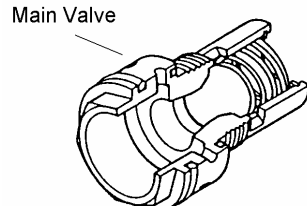

Fig. 10-B

After having cleaned all parts and changed the damaged ones the Mixing Valve may be assembled in the opposite way.

- (1) Screw the Main valve unit inside the body. Then fasten the Main valve unit. Pay attention to the required torque.

Valve Size	Fastening Torque
1/2"	450 kgf • cm
3/4"	450 kgf • cm
1"	800 kgf • cm
1 1/2"	1.300 kgf • cm

- (2) Screw the adjust unit carefully inside the bimetal unit (Fig. 12-A). Then insert the unit inside the valve by turning slightly to the right and left (Fig. 12-B). Pay attention, that the O-Rings of the bimetal and adjust unit are not damaged. Fasten the bush (No. 35) with a torque of 100 kgf • cm. Then screw out the adjust unit slightly (Fig.12-C).

Fig. 12-A

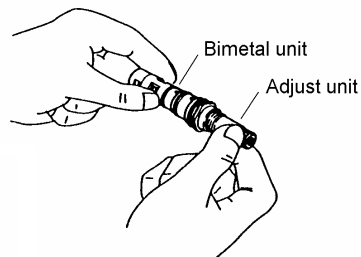

Fig. 12-C

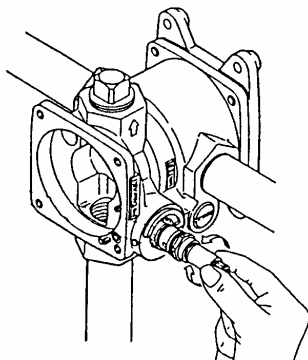
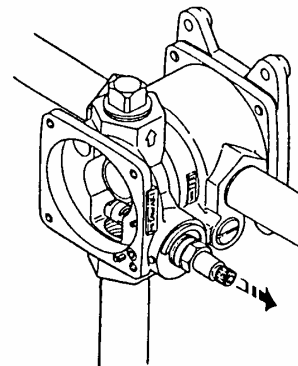

Fig. 12-B

- (2) Insert the diaphragm unit into the body. Pay attention that the pin hole of the guide (No. 13) will meet the pin of the body (Fig. 13-A).

Furthermore the pin hole of the diaphragm should also meet the related pin of the body (Fig. 13-C).

Fig. 13-A

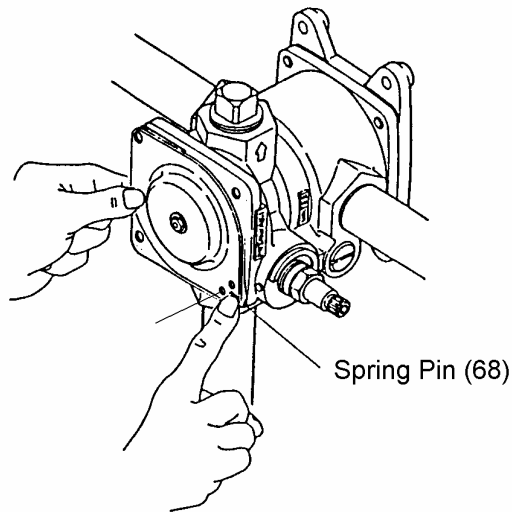
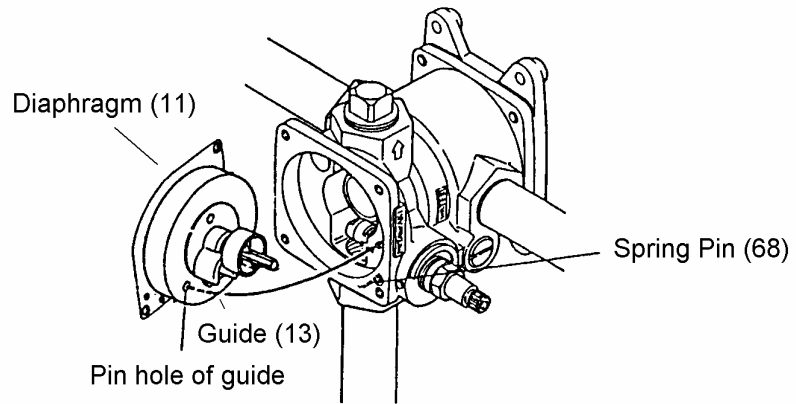

Fig. 13-B

- (3) Connect the cover with the body. The pin hole of the cover must meet the pin of the body (Fig. 14).

Fasten the cover bolts with the following torque equally crosswise:

Valve Size	Fastening Torque
1/2"	70 kgf • cm
3/4"	70 kgf • cm
1"	150 kgf • cm
1 1/2"	150 kgf • cm

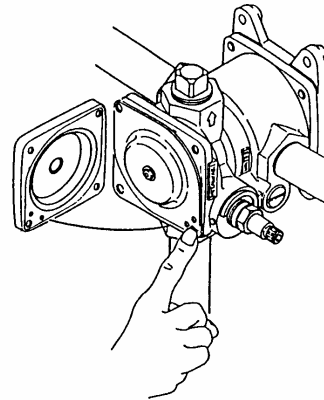

Fig. 14

- (4) Adjust the hot water temperature to 40°C (104°F) by turning the shaft of the adjusting unit (Fig. 15).

After adjustment of the 40°C (104°F) fix the handle to the adjust unit so that the red safety button of the handle will correspond with the red marker on the body (Fig. 16).

Fig. 15

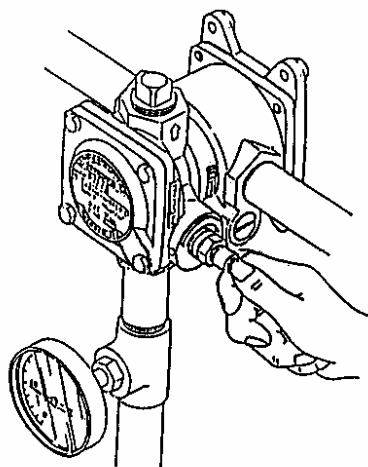
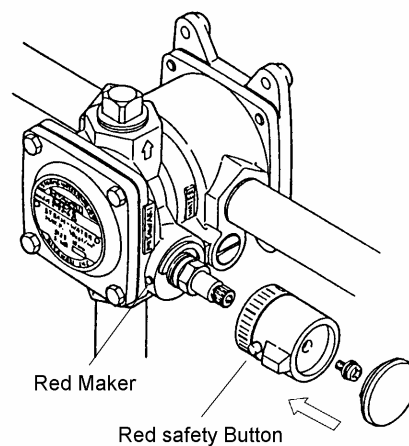

Fig. 16



- 1 Body
- 2 Cover
- 4 ~ 10 Main Valve Unit
- 11 ~ 18 Diaphragm Unit
- 19 ~ 27 + 63 ~ 65 Bimetal Unit
- 28 ~ 34 Adjust Unit
- 35 Bush
- 36 ~ 41 Handle Unit
- 42 ~ 46 Strainer Unit
- 48, 71 Bolt
- 56 ~ 57 Pressure Valve Unit (only 1/2", 3/4")

